

REVIEW for THIS WEEKS BIG TEST

(Momentum, Impulse, & Centripetal)

MOMENTUM & IMPULSE

1 - Know momentum, & hows its different from inertia (equ. & units)

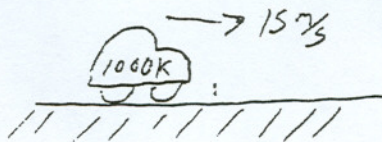

2 - Know Conservation of Momentum -

In Collision where objects stick

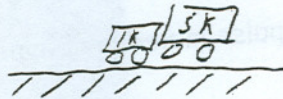
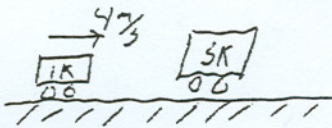

In explosion -



In collision where they don't stick (Very rare)

3) Impulse & Basic Impulse equation.

4) Know Impulse = Change in momentum

5) Momentum and impulse mixed problems -

- Collision

A .2kg bullet traveling 200 m/s strikes & imbeds in 3 kg block. Collision time is .01 seconds.



Find-

- velocity of pair after collision

- Change in momentum on ether
(Same as Impulse)

- Force on ether.

- Explosion

The two lab carts shown are held Together by spring, Spring is released
As shown, Release time is .2 sec.

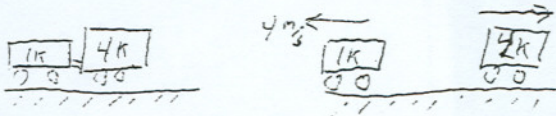

Find-

- velocity of 4 kg after collision

- Change in momentum on ether
(Same as Impulse)

- Force on ether.

Momentum & Impulse Questions

1) Which object has the most inertia? ... Which has most momentum?

- (1) a 0.001-kilogram bumblebee traveling at 2 meters per second
- (2) a 0.1-kilogram baseball traveling at 20 meters per second
- (3) a 5-kilogram bowling ball traveling at 3 meters per second
- (4) a 10.-kilogram sled at rest

2) What is the momentum of a 1,200-kilogram car traveling at 15 meters per second due east?

- (1) 80. kg•m/s due east
- (2) 80. kg•m/s due west
- (3) 1.8×10^4 kg•m/s due east
- (4) 1.8×10^4 kg•m/s due west

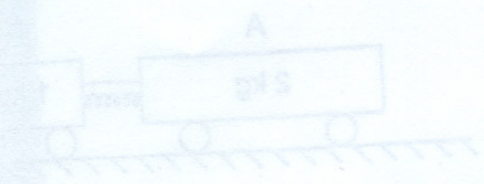

3) What is the speed of a 1.0×10^3 -kilogram car that has a momentum of 2.0×10^4 kilogram•meters per second east?

- (1) 5.0×10^{-2} m/s
- (2) 2.0×10^1 m/s
- (3) 1.0×10^4 m/s
- (4) 2.0×10^7 m/s

4) If the speed of a car is doubled, the ~~kinetic energy~~ ^{the momentum} of the car is

- (1) quadrupled
- (2) quartered
- (3) doubled
- (4) halved

5

A 2.0-kilogram cart moving due east at 6.0 meters per second collides with a 3.0-kilogram cart moving due west. The carts stick together and come to rest after the collision. What was the initial speed of the 3.0-kilogram cart?

- (1) 1.0 m/s
- (2) 6.0 m/s
- (3) 9.0 m/s
- (4) 4.0 m/s

6+7

The diagram shows a compressed spring between two carts initially at rest on a horizontal frictionless surface. Cart A has a mass of 2 kilograms and cart B has a mass of 1 kilogram. A string holds the carts together.

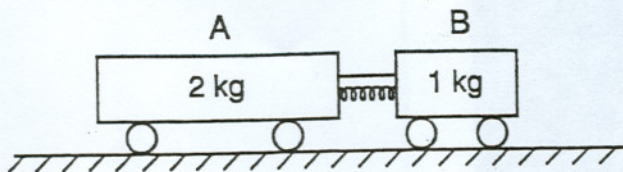

6. After the string is cut and the two carts move apart, the magnitude of which quantity is the same for both carts?

- (1) momentum
- (2) velocity
- (3) inertia
- (4) kinetic energy

7. How does velocity of A compare to B

8. What occurs when the string is cut and the carts move apart?

- (1) The magnitude of the acceleration of cart A is one-half the magnitude of the acceleration of cart B.
- (2) The length of time that the force acts on cart A is twice the length of time the force acts on cart B.
- (3) The magnitude of the force exerted on cart A is one-half the magnitude of the force exerted on cart B.
- (4) The magnitude of the impulse applied to cart A is twice the magnitude of the impulse applied to cart B.

4

A 1.2-kilogram block and a 1.8-kilogram block are initially at rest on a frictionless, horizontal surface. When a compressed spring between the blocks is released, the 1.8-kilogram block moves to the right at 2.0 meters per second, as shown.

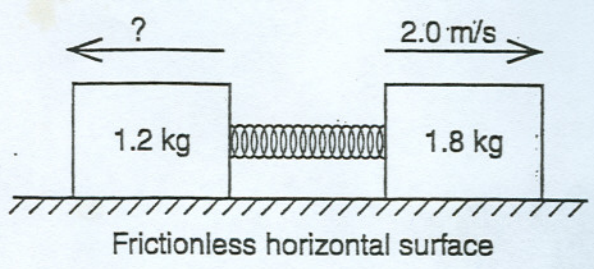

9

What is the speed of the 1.2-kilogram block after the spring is released?

- (1) 1.4 m/s
- (2) 2.0 m/s
- (3) 3.0 m/s
- (4) 3.6 m/s

10

How does Momentum of 1.2K compare to 1.8K

11

A lab cart is loaded with different masses and moved at various velocities. Which diagram shows the cart-mass system with the greatest inertia?

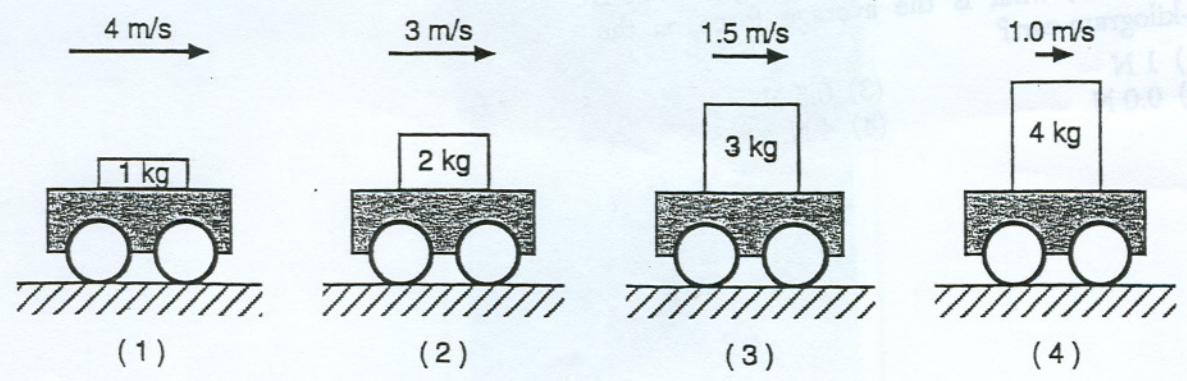

12

In the diagram below, a 60.-kilogram rollerskater exerts a 10.-newton force on a 30.-kilogram rollerskater for 0.20 second.

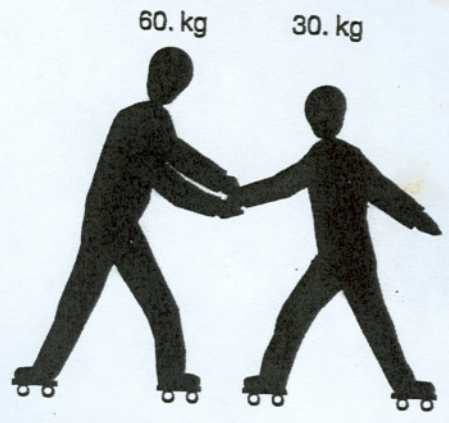

What is the magnitude of the impulse applied to the 30.-kilogram rollerskater?

- (1) 50. N•s
- (2) 2.0 N•s
- (3) 6.0 N•s
- (4) 12 N•s

13

How does velocity 60K compare to velocity 30K

14

7 Two carts are pushed apart by an expanding spring, as shown in the diagram below.

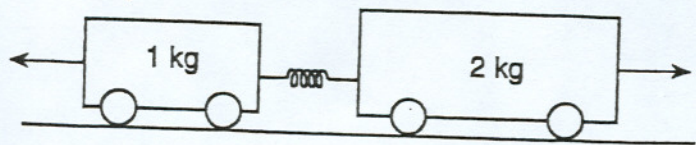

If the average force on the 1-kilogram cart is 1 newton, what is the average force on the 2-kilogram cart?

- (1) 1 N
- (2) 0.0 N
- (3) 0.5 N
- (4) 4 N

15 At the circus, a 100.-kilogram clown is fired at 15 meters per second from a 500.-kilogram cannon. What is the recoil speed of the cannon?

- (1) 75 m/s (3) 3.0 m/s
 (2) 15 m/s (4) 5.0 m/s

16 A 3.0-kilogram steel block is at rest on a frictionless horizontal surface. A 1.0-kilogram lump of clay is propelled horizontally at 6.0 meters per second toward the block as shown in the diagram below.

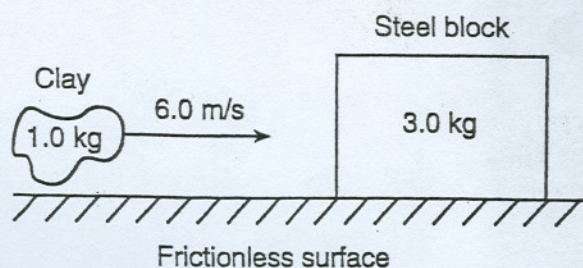

Upon collision, the clay and steel block stick together and move to the right with a speed of

- (1) 1.5 m/s (3) 3.0 m/s
 (2) 2.0 m/s (4) 6.0 m/s

17 In the diagram below, a block of mass M initially at rest on a frictionless horizontal surface is struck by a bullet of mass m moving with horizontal velocity v .

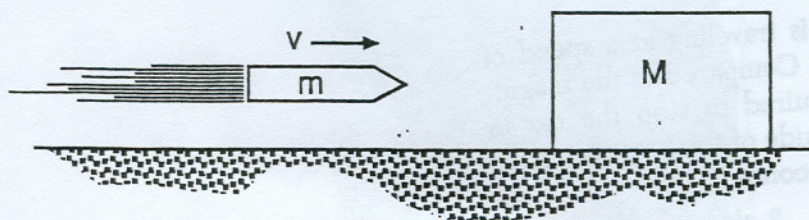

What is the velocity of the bullet-block system after the bullet embeds itself in the block?

- (1) $\left(\frac{M+v}{M}\right)m$ (3) $\left(\frac{m+v}{M}\right)m$
 (2) $\left(\frac{m+M}{m}\right)v$ (4) $\left(\frac{m}{m+M}\right)v$

Base your answers to questions 66 through 68 on the information and diagram below.

A 1000.-kilogram empty cart moving with a speed of 6.0 meters per second is about to collide with a stationary loaded cart having a total mass of 5000. kilograms, as shown. After the collision, the carts lock and move together. [Assume friction is negligible.]

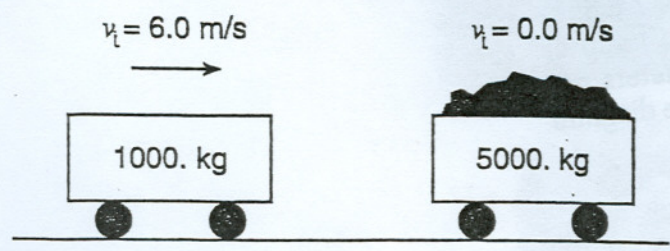

- (18) 66 Calculate the speed of the combined carts after the collision. [Show all work, including the equation and substitution with units.] [2]
- (19) 67 Calculate the kinetic energy of the combined carts after the collision. [Show all work, including the equation and substitution with units.] [2]
- (20) 68 How does the kinetic energy of the combined carts after the collision compare to the kinetic energy of the carts before the collision? [1]

Impulse Questions

- (21) A 2,400-kilogram car is traveling at a speed of 20. meters per second. Compared to the magnitude of the force required to stop the car in 12 seconds, the magnitude of the force required to stop the car in 6.0 seconds is

1 half as great	3 the same
2 twice as great	4 four times as great

- (22) 41 Which two quantities can be expressed using the same units?
 - (1) energy and force
 - (2) impulse and force
 - (3) momentum and energy
 - (4) impulse and momentum

22

11 A 0.10-kilogram model rocket's engine is designed to deliver an impulse of 6.0 newton-seconds. If the rocket engine burns for 0.75 second, what average force does it produce?

- (1) 4.5 N
- (2) 8.0 N
- (3) 45 N
- (4) 80. N

23

A 1000-kilogram car traveling due east at 15 meters per second is hit from behind and receives a forward impulse of 6000 newton-seconds. Determine the magnitude of the car's change in momentum due to this impulse. [1]

Answers

- | | | | | |
|-----|---------------------------|----------------------------------|----------|--|
| 1-4 | 6-1 | 11-4 | 16-1 | 21-2 |
| 2-3 | 7- $V_A = \frac{1}{2}V_B$ | 12-2 | 17-4 | 22-4 |
| 3-2 | 8-1 | 13- $V_{A0} = \frac{1}{2}V_{B0}$ | 18-1 m/s | 23-2 |
| 4-3 | 9-3 | 14-1 | 19-3000J | 23- $\Delta P = J = 6000 \text{ N}\cdot\text{sec}$ |
| 5-4 | 10-same | 15-3 | 20-less | |