

This year there were 23 of 85 credits possible or about 27% of test

15 If 20 joules of work is used to transfer 20 coulombs of charge through a 20-ohm resistor, the potential difference across the resistor is

- (1) 1 V
- (2) 20 V
- (3) 0.05 V
- (4) 400 V

16 At 20°C, four conducting wires made of different materials have the same length and the same diameter. Which wire has the *least* resistance?

- (1) aluminum
- (2) gold
- (3) nichrome
- (4) tungsten

17 Three identical lamps are connected in parallel with each other. If the resistance of each lamp is  $X$  ohms, what is the equivalent resistance of this parallel combination?

- (1)  $X \Omega$
- (2)  $\frac{X}{3} \Omega$
- (3)  $3X \Omega$
- (4)  $\frac{3}{X} \Omega$

18 A 2.0-ohm resistor and a 4.0-ohm resistor are connected in series with a 12-volt battery. If the current through the 2.0-ohm resistor is 2.0 amperes, the current through the 4.0-ohm resistor is

- (1) 1.0 A
- (2) 2.0 A
- (3) 3.0 A
- (4) 4.0 A

19 The diagram below shows a beam of electrons fired through the region between two oppositely charged parallel plates in a cathode ray tube.

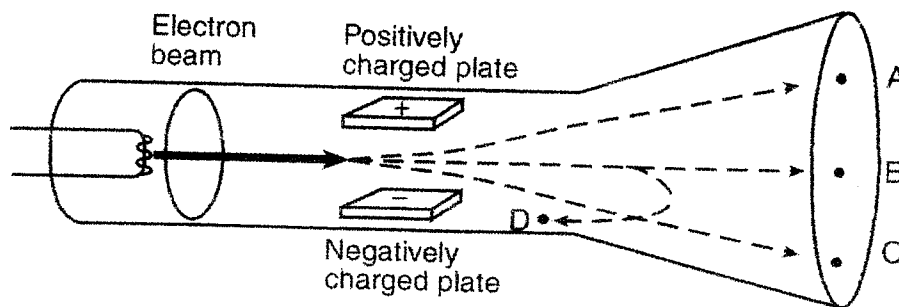

After passing between the charged plates, the electrons will most likely travel path

- (1) A
- (2) B
- (3) C
- (4) D

20 In which circuit would current flow through resistor  $R_1$ , but not through resistor  $R_2$  while switch S is open?

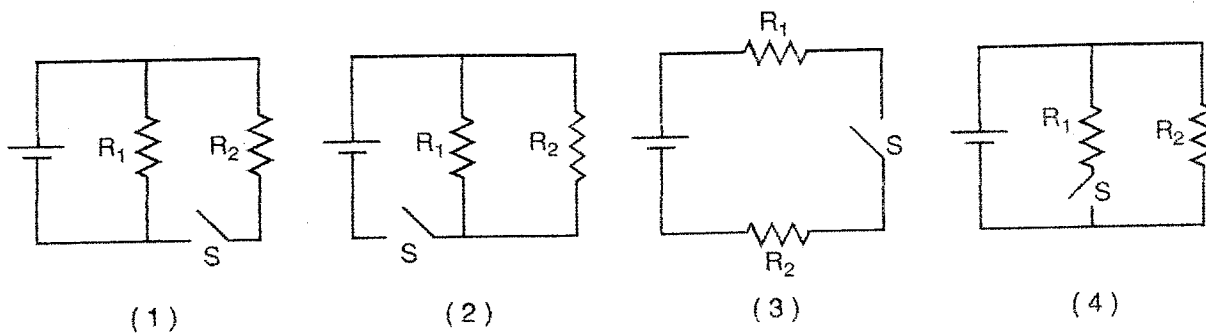

21 The diagram below represents a 0.5-kilogram bar magnet and a 0.7-kilogram bar magnet with a distance of 0.2 meter between their centers.

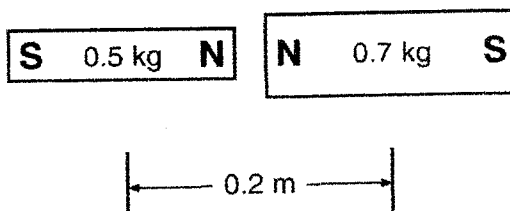

Which statement best describes the forces between the bar magnets?

- (1) Gravitational force and magnetic force are both repulsive.
- (2) Gravitational force is repulsive and magnetic force is attractive.
- (3) Gravitational force is attractive and magnetic force is repulsive.
- (4) Gravitational force and magnetic force are both attractive.

31) If an object has a net negative charge of 4.0 coulombs, the object possesses

- (1)  $6.3 \times 10^{18}$  more electrons than protons
- (2)  $2.5 \times 10^{19}$  more electrons than protons
- (3)  $6.3 \times 10^{18}$  more protons than electrons
- (4)  $2.5 \times 10^{19}$  more protons than electrons

43 What is the current in a 100.-ohm resistor connected to a 0.40-volt source of potential difference?

- (1) 250 mA
- (2) 40. mA
- (3) 2.5 mA
- (4) 4.0 mA

42 In the electric circuit diagram below, possible locations of an ammeter and a voltmeter are indicated by circles 1, 2, 3, and 4.

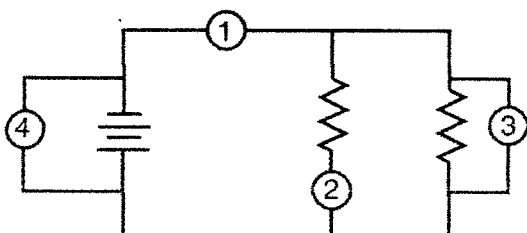

Where should an ammeter be located to correctly measure the total current and where should a voltmeter be located to correctly measure the total voltage?

- (1) ammeter at 1 and voltmeter at 4
- (2) ammeter at 2 and voltmeter at 3
- (3) ammeter at 3 and voltmeter at 4
- (4) ammeter at 1 and voltmeter at 2

44 A 150-watt lightbulb is brighter than a 60.-watt lightbulb when both are operating at a potential difference of 110 volts. Compared to the resistance of and the current drawn by the 150-watt lightbulb, the 60.-watt lightbulb has

- (1) less resistance and draws more current
- (2) less resistance and draws less current
- (3) more resistance and draws more current
- (4) more resistance and draws less current

45 What is the minimum equipment needed to determine the power dissipated in a resistor of unknown value?

- (1) a voltmeter, only
- (2) an ammeter, only
- (3) a voltmeter and an ammeter, only
- (4) a voltmeter, an ammeter, and a stopwatch

Base your answers to questions 61 through 63 on the information below.

The centers of two small charged particles are separated by a distance of  $1.2 \times 10^{-4}$  meter. The charges on the particles are  $+8.0 \times 10^{-19}$  coulomb and  $+4.8 \times 10^{-19}$  coulomb, respectively.

- 61 Calculate the magnitude of the electrostatic force between these two particles. [Show all work, including the equation and substitution with units.] [2]
- 62 On the axes *in your answer booklet*, sketch a graph showing the relationship between the magnitude of the electrostatic force between the two charged particles and the distance between the centers of the particles. [1]
- 63 On the diagram *in your answer booklet*, draw *at least four* electric field lines in the region between the two positively charged particles. [1]
- 52 The diagram below represents two electrons,  $e_1$  and  $e_2$ , located between two oppositely charged parallel plates.

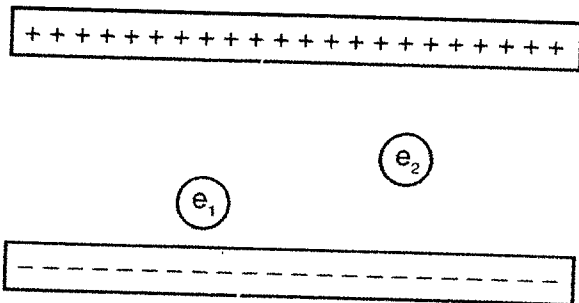

- 53 A length of copper wire and a 1.00-meter-long silver wire have the same cross-sectional area and resistance at  $20^\circ\text{C}$ . Calculate the length of the copper wire. [Show all work, including the equation and substitution with units.] [2]

Compare the magnitude of the force exerted by the electric field on  $e_1$  to the magnitude of the force exerted by the electric field on  $e_2$ . [1]

Base your answers to questions 67 through 69 on the information below.

A 5.0-ohm resistor, a 10.0-ohm resistor, and a 15.0-ohm resistor are connected in parallel with a battery. The current through the 5.0-ohm resistor is 2.4 amperes.

- 67 In the space *in your answer booklet*, using the circuit symbols found in the *Reference Tables for Physical Setting/Physics*, draw a diagram of this electric circuit. [1]
- 68 Calculate the amount of electrical energy expended in the 5.0-ohm resistor in 2.0 minutes. [Show all work, including the equation and substitution with units.] [2]
- 69 A 20.0-ohm resistor is added to the circuit in parallel with the other resistors. Describe the effect the addition of this resistor has on the amount of electrical energy expended in the 5.0-ohm resistor in 2.0 minutes. [1]

- 15 20
- 16 21
- 17 34
- 18 42
- 19 43
- 44
- 45

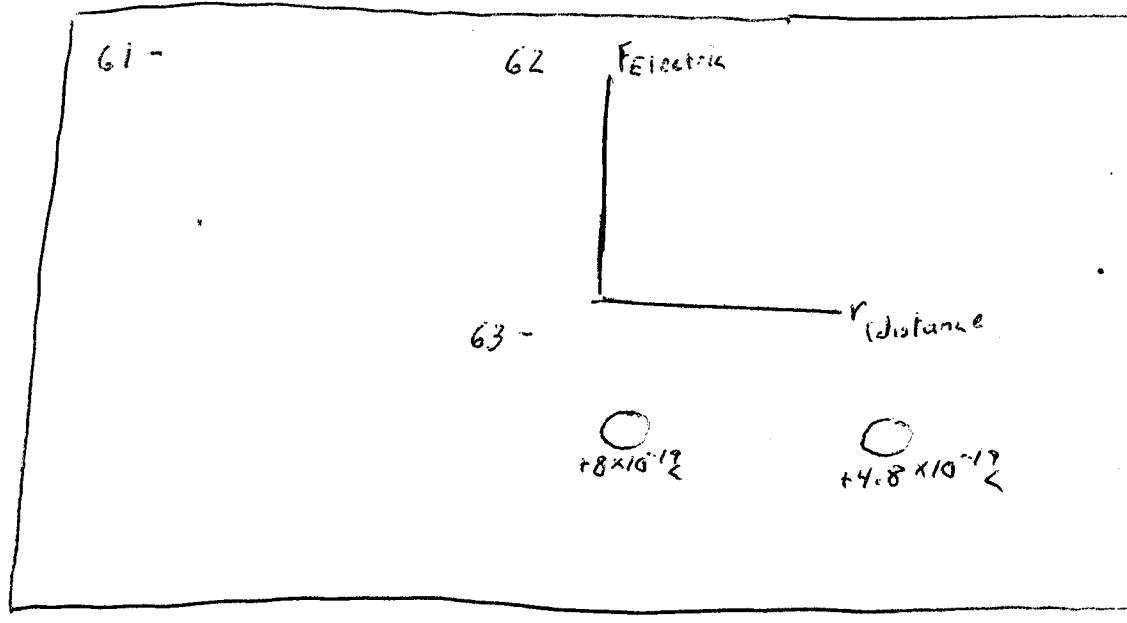

52 - \_\_\_\_\_

53 - \_\_\_\_\_

67

68

69

| Credits<br>of 23 | %     | Credits<br>of 25 | Scaled<br>Regents<br>Score |
|------------------|-------|------------------|----------------------------|
| 23.0             | 100.0 | 85.0             | 100                        |
| 22.0             | 95.7  | 81.3             | 97                         |
| 21.0             | 91.3  | 77.6             | 94                         |
| 20.0             | 87.0  | 73.9             | 91                         |
| 19.0             | 82.6  | 70.2             | 87                         |
| 18.0             | 78.3  | 66.5             | 85                         |
| 17.0             | 73.9  | 62.8             | 81                         |
| 16.0             | 69.6  | 59.1             | 78                         |
| 15.0             | 65.2  | 55.4             | 74                         |
| 14.0             | 60.9  | 51.7             | 71                         |
| 13.0             | 56.5  | 48.0             | 67                         |
| 12.0             | 52.2  | 44.3             | 63                         |
| 11.0             | 47.8  | 40.7             | 60                         |
| 10.0             | 43.5  | 37.0             | 56                         |
| 9.0              | 39.1  | 33.3             | 51                         |
| 8.0              | 34.8  | 29.6             | 47                         |
| 7.0              | 30.4  | 25.9             | 42                         |
| 6.0              | 26.1  | 22.2             | 37                         |

- 15 - 1
- 16 - 2
- 17 - 2
- 18 - 2
- 19 - 1
- 20 - 1
- 21 - 3
- 34 - 2
- 42 - 1
- 43 - 4
- 44 - 4
- 45 - 3

61 -

$$F = k \frac{q_1 q_2}{r^2}$$

$$= 9 \times 10^9 \frac{N \cdot m^2}{C^2} \frac{(8 \times 10^{-19} C)(4.8 \times 10^{-19} C)}{(1.2 \times 10^{-4} m)^2}$$

$$F = 2.4 \times 10^{-19} N$$

62

63 -

52 - same on Each

53 -  $R = \left( \rho \frac{L}{A} \right)_{\text{Copper}} = \left( \rho \frac{L}{A} \right)_{\text{Silver}}$

$\rho_{\text{Copper}} L_{\text{Copper}} = \rho_{\text{Silver}} L_{\text{Silver}}$

$1.72 \times 10^{-8} \Omega \cdot m (L_{\text{Copper}}) = 1.59 \times 10^{-8} \Omega \cdot m (L_{\text{m}})$

$L_{\text{Copper}} = .924 m$

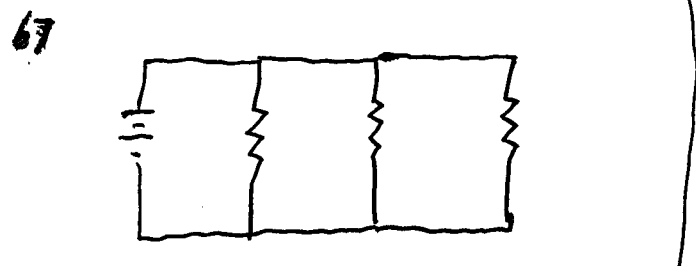

68

$$W = I^2 R t$$

$$= (2.4 A)^2 (5 \Omega) (120 s)$$

$$W = 3.5 \times 10^3 \text{ Joules}$$

69 - Energy used in 5  $\Omega$   
 is same

| Credits of 23 | %     | Credits of 25 | Scaled Regents Score |
|---------------|-------|---------------|----------------------|
| 23.0          | 100.0 | 85.0          | 100                  |
| 22.0          | 95.7  | 81.3          | 97                   |
| 21.0          | 91.3  | 77.6          | 94                   |
| 20.0          | 87.0  | 73.9          | 91                   |
| 19.0          | 82.6  | 70.2          | 87                   |
| 18.0          | 78.3  | 66.5          | 85                   |
| 17.0          | 73.9  | 62.8          | 81                   |
| 16.0          | 69.6  | 59.1          | 78                   |
| 15.0          | 65.2  | 55.4          | 74                   |
| 14.0          | 60.9  | 51.7          | 71                   |
| 13.0          | 56.5  | 48.0          | 67                   |
| 12.0          | 52.2  | 44.3          | 63                   |
| 11.0          | 47.8  | 40.7          | 60                   |
| 10.0          | 43.5  | 37.0          | 56                   |
| 9.0           | 39.1  | 33.3          | 51                   |
| 8.0           | 34.8  | 29.6          | 47                   |
| 7.0           | 30.4  | 25.9          | 42                   |
| 6.0           | 26.1  | 22.2          | 37                   |